

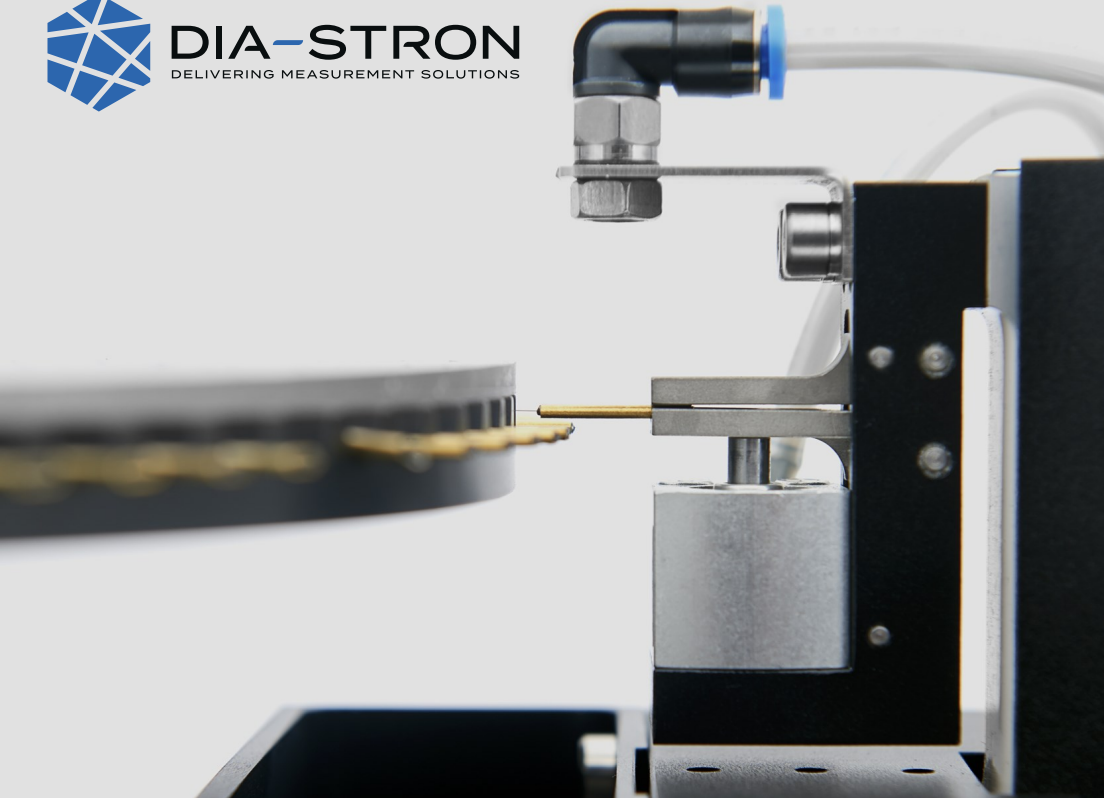

DIA-STRON
DELIVERING MEASUREMENT SOLUTIONS



Hair Fibre Testing Instrumentation

Dia-Stron is the leading manufacturer of automated measurement systems for both single hair fibres and hair tresses. We have a unique and comprehensive approach to metrology, from design and development to production of complete scientific systems.

Our first product launch in the late 1980s was a miniature tensile tester with a micro-processor control and digital data output into a basic software package. By 1992, we were introducing our first automated tensile tester: a cassette based system that allowed up to 100 single fibres to be measured in an automated sequence, without any need for manual reloading.

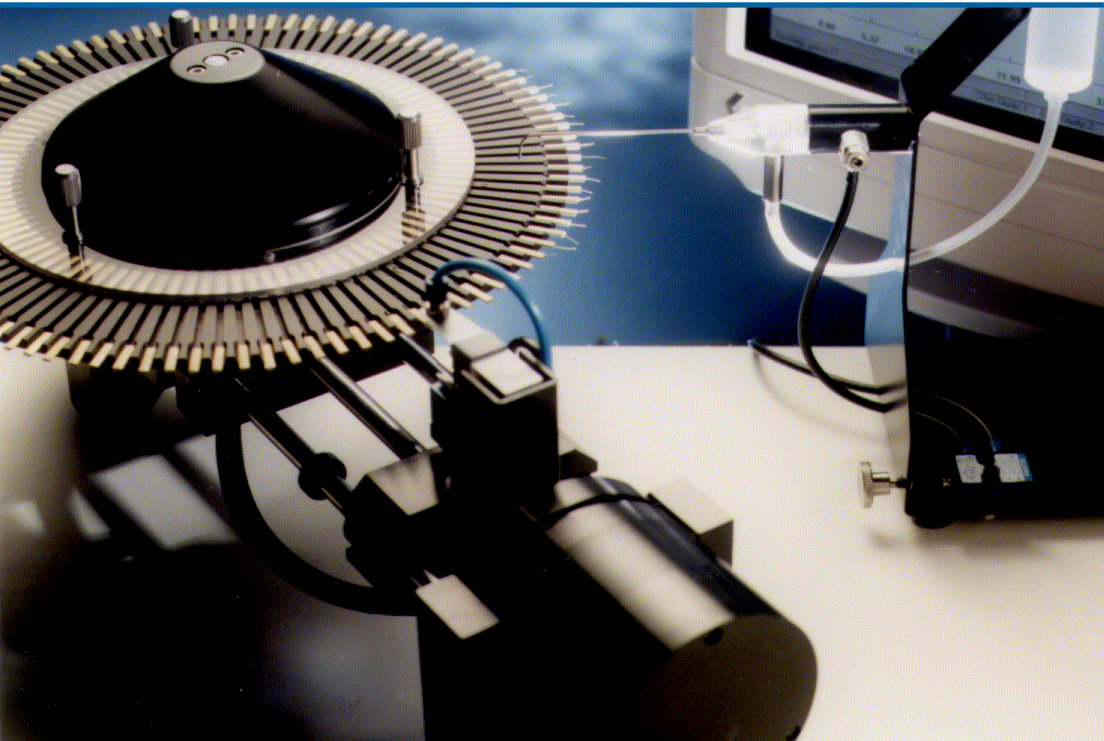

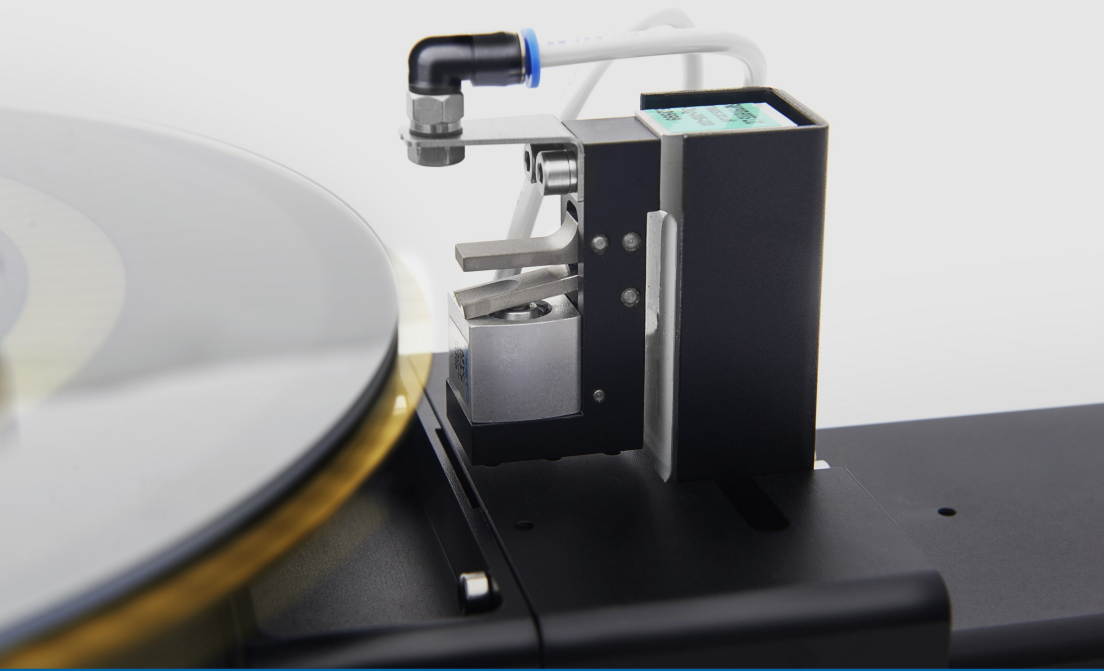

Since then we've constantly driven innovations for our customers' ever changing requirements – most notably by widening our module options beyond tensile testing to include dimensional, fatigue, bending and torsional testing, as well as incorporating automation and additional diameter measurement modules.

From the beginning our mission has been to develop new and improved fibre measurement techniques and approaches, while still producing results of the highest quality.

Dia-Stron instrumentation can be found in the R&D laboratories of multinational organisations, local companies, universities and CROs, from research to raw ingredients, from formulation to consumer product manufacture.

Our measurement systems can be used to develop new hair care ingredients and technologies, to evaluate technical performance of new formulations, and to advance hair fibre science. They also provide an evidence-based claims support package, substantiating claims referring to the efficacy, benefits or improvements in hair attributes as a result of using your hair care products and appliances.

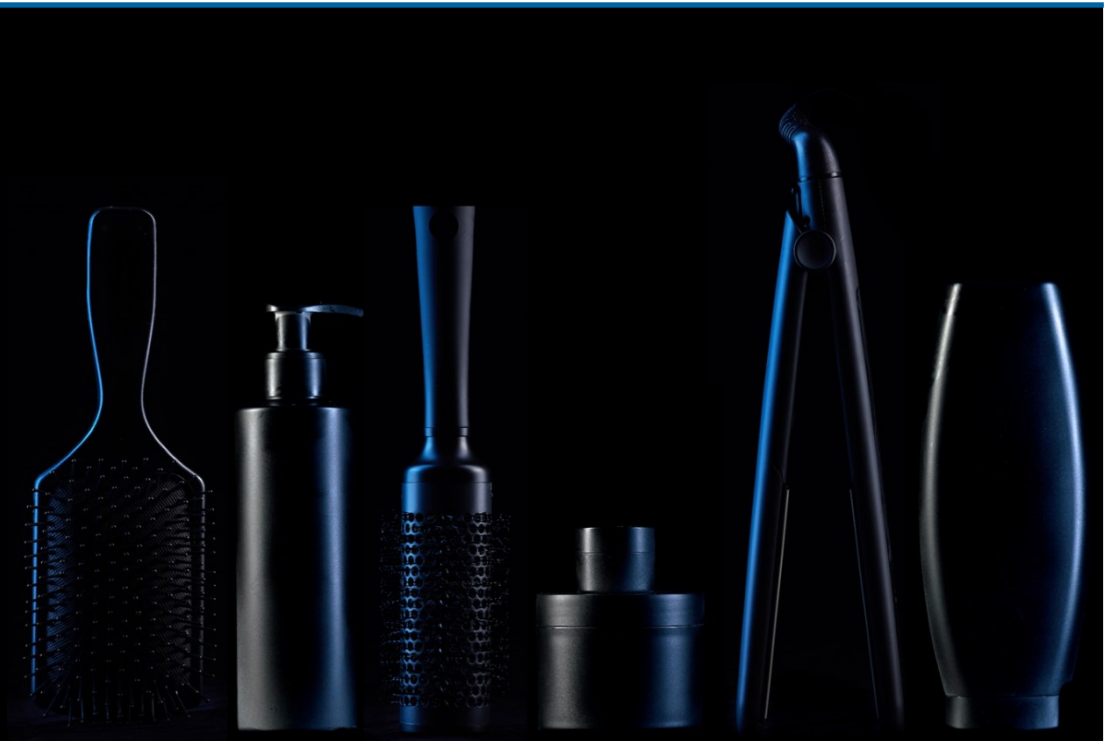



Claims Support

Hair Tresses

- Ease of combing/conditioning claims
- Detangling claims
- Manageability claims
- Softness/suppleness claims
- Volume/body claims
- Combability after styling claims
- Styling hold/flexibility claims
- Long lasting claims

Single Hair Fibres

- Anti breaking/strength claims
- Thickening claims
- Damage prevention/repair claims
- Hydration/moisturising claims
- Repeated grooming claims
- Heat protection claims
- Elasticity claims
- Depilatory cream claims



Tress Testing

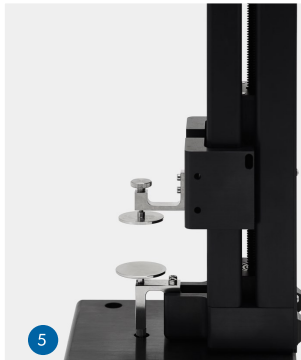
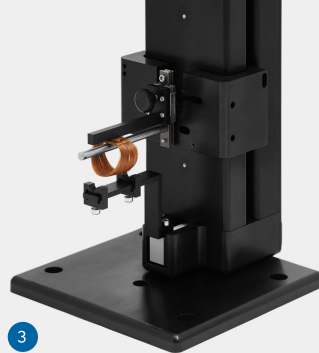

MTT175 — All-in-one Tress Testing Solution

The MTT175 is a multi-purpose instrument with a range of accessories to suit your individual testing requirements; combing (1), hair and substrate friction (2), curl compression (3), volume (4), tack and adhesion (product only) (5) and 3-point bend (6).

For claims ranging from “detangling”, “softness” and “hold” to “flexibility”, “volume” and “smoothness”, this multi-use capability makes it the most cost-effective, entry-level equipment solution for hair tress testing.

Single Fibre Testing

A close-up, low-angle shot of a curved, black, multi-fiber optical cable. The cable is densely packed with fibers, and the gold-colored connectors are visible along the outer edge. The text "Single Fibre Testing" is overlaid in white, bold, sans-serif font across the center of the image.

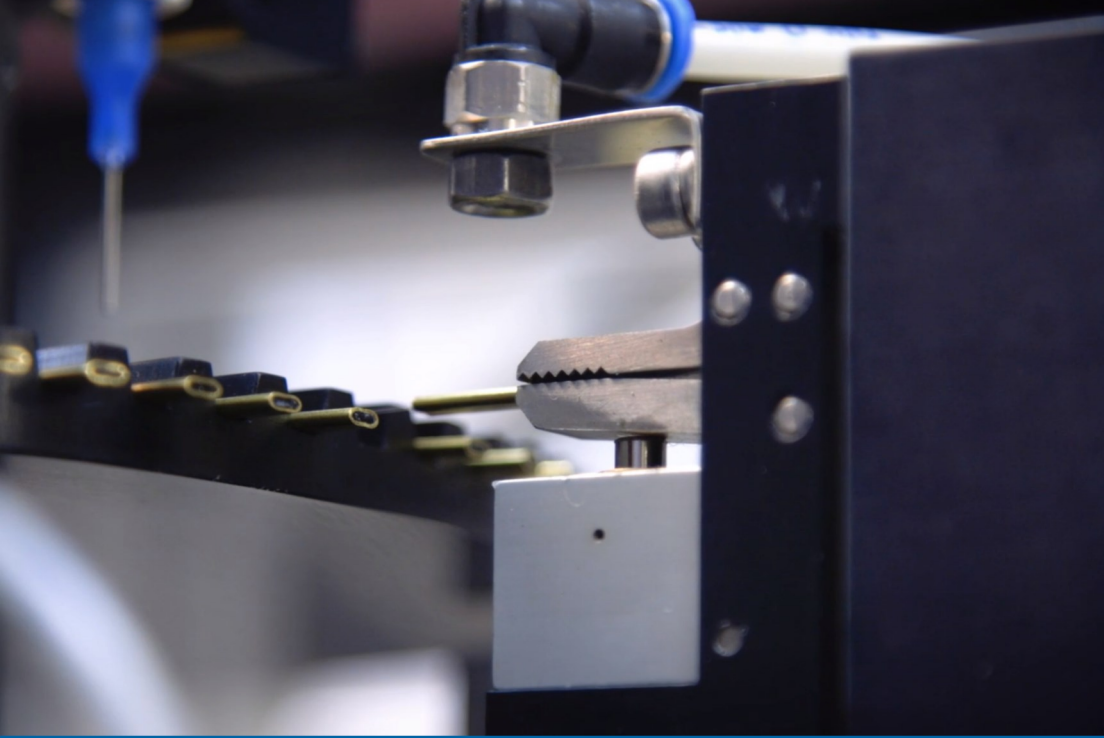

MTT690 — Miniature Tensile Tester

The MTT690 is an automated, consistent and efficient instrument designed to measure the tensile properties of hair. It offers a high throughput of 100 single specimens, in either a dry or wet state. The MTT690 measures the tensile properties of single hair fibres by stretching them to a specified percentage or to failure, and is primarily used to support “strength”, “hydration” and “damage repair” claims.

FDAS770 — Fibre Dimensional Analysis System

The FDAS770 utilises a Laser Scanning Micrometer to allow accurate, non-contact dimensional measurement of fibres for the normalisation of mechanical (stress) data. It allows for cross-sectional area calculation, with fully automated fibre rotation and translation. A Dynamic Swelling Module (DSM770) can be incorporated for swelling and wet diameter measurements. Primarily used for “thickening” product claims or wettability performance, and to normalise mechanical testing with fibre dimensional data.

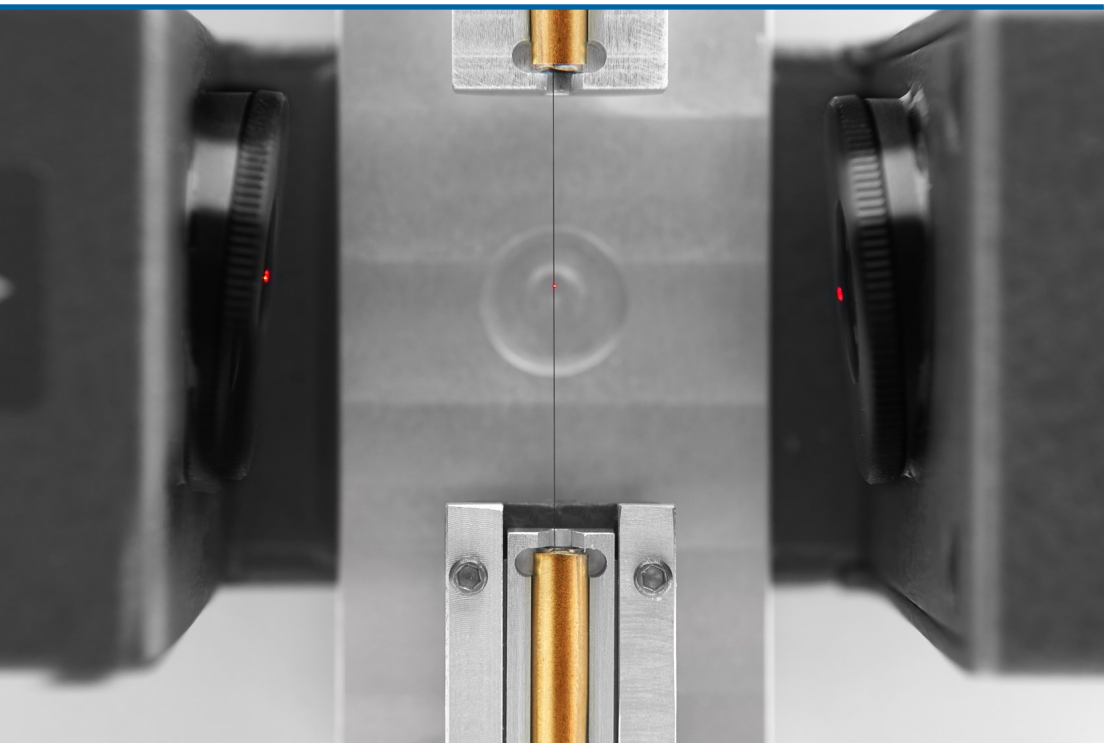



CYC802 — Cyclic Fatigue

The CYC802 measures the dynamic strength of hair fibres by subjecting them to repeated cyclic tensile deformations until failure, simulating repeated grooming. Up to four cyclic modules can be integrated on an automated platform, offering high-throughput testing using up to four 50-fibre linear cassettes in a Cassette Hotel. An ideal technique for evaluating the damage caused by treatments (such as heat or chemical damage), and for claims relating to “strengthening” or “damage protection/prevention”.

FTT950 — Fibre Torsion Tester

Our FTT950 systems allows torsion force, torsion/shear modulus (with dimensional data), torsion stress relaxation and other parameters to be calculated, as well as being fully automated for a high throughput and efficient workflow. Hair fibres are pulled taught and twisted up to 360° against a balance, directly measuring torsional properties. Torsion is particularly useful for measuring the impact of products and treatments on the hair fibre cuticle layers and cortex matrix e.g. oil treatments making hair fibres softer.

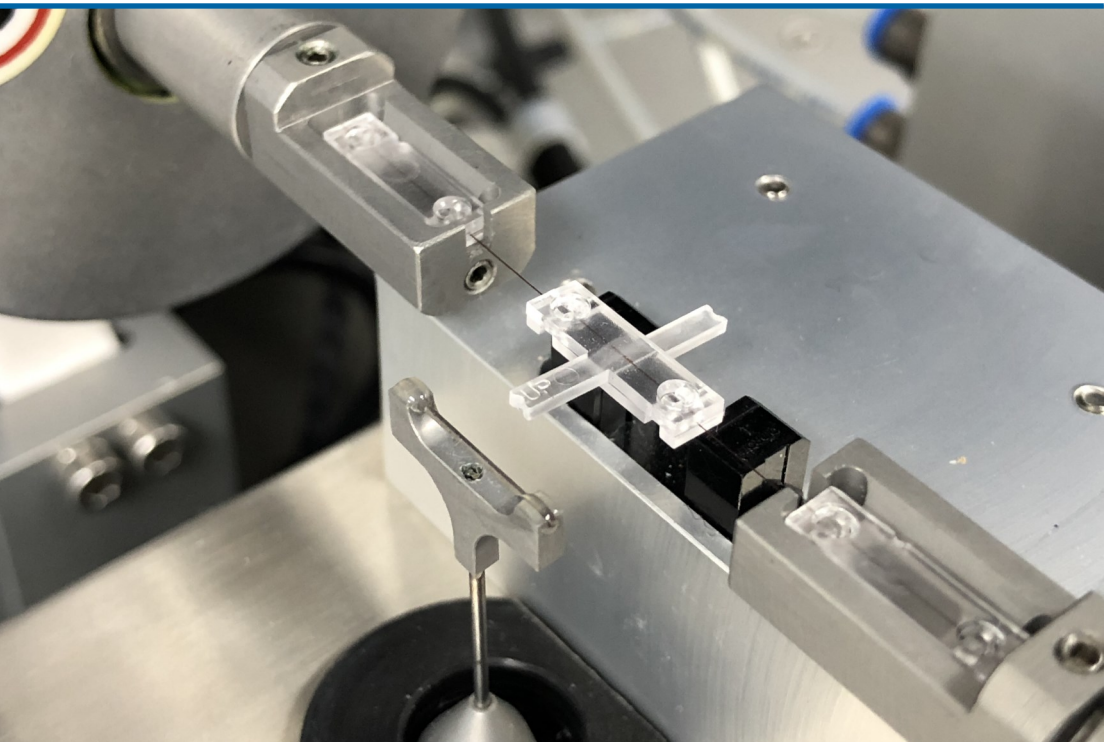

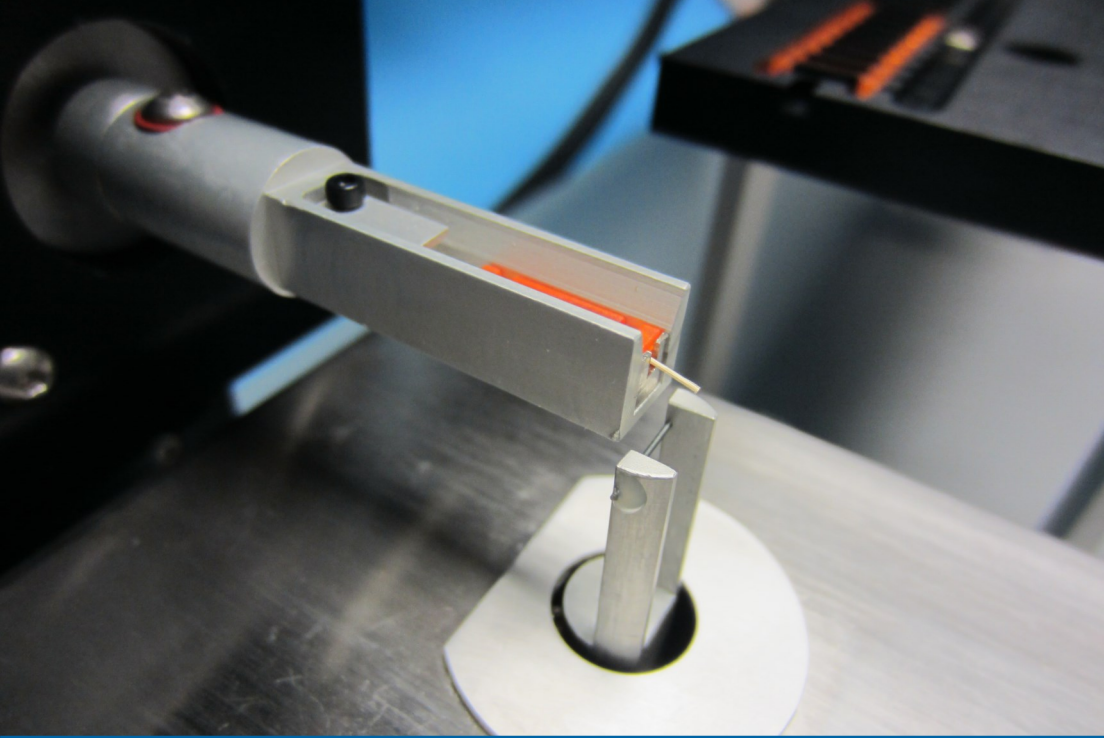

FBS900 — Fibre Bending System

The FBS900 fibre bending system is based on the single cantilever method, where the fibre specimen is bent against a pin and the bending force is measured using a micro-balance. The bending force and bending stress relaxation can be calculated, as well as the bending modulus (when combined with dimensional data). Applications include measuring how cuticle damage affects hair bending stiffness, impact of styling products on fibre rigidity and formulation development for mascaras and shaving products.

ALS1500 — Automated Loading System

All our measurement modules can be used in conjunction with our automation platform, delivering high throughput testing of hair fibres for maximum productivity. The “Pick & Place” mechanism transports hair fibre specimens from storage cassette to measurement modules and back continuously, without the need for user intervention, 24/7. An additional multi-tasking option further increases testing efficiency.

For optimum sample capacity and throughput, the Cassette Hotel can be loaded with 4 cassettes equating to 200 hair fibre specimens.

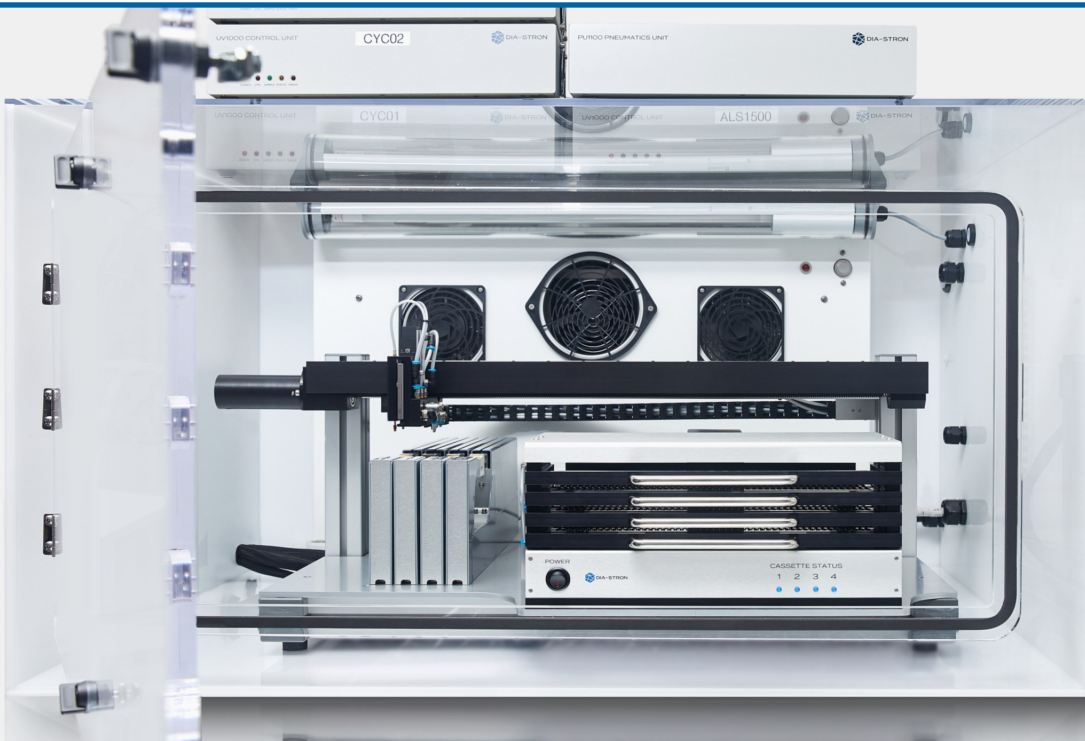



Contract Testing

Our dedicated hair testing laboratory was established to provide customers with a wide range of fibre/tress testing services to substantiate product claims. Our skilled laboratory staff and purpose-built instrumentation range enable us to conduct entire studies, big or small, in-house, using testing methodologies developed by experts with a wealth of practical experience in the hair care industry.

Our contract testing service is an efficient, cost-effective way to ensure you receive valid, reliable and reproducible results - contact us today for a bespoke quotation!

Contact Us

Dia-Stron Ltd.

9 Focus Way
Andover, Hampshire
SP10 5NY | United Kingdom
T. +44(0) 1264 334700

Dia-Stron Inc.

9 Trenton Lakewood Road
Clarksburg, NJ
08510 | U.S.A.
T. +1 (609) 454 6008

Email: enquiry@diastron.com

www.diastron.com